



Stif Back® II Area Wall



Shown with a Premiere picture window with optional hanging brackets



Construction.

- Deep corrugation of the Stif Back II design provides superior strength to meet virtually every application.
- Designed as our strongest area wall product.
- Constructed of heavy gauge galvanized steel to withstand the pressure from heavy soil.
- One-piece construction.
- Flat, pre-punched flanges allow easy attachment for bolt to frame or anchor to foundation applications.
- Heavy 3/4" top is rolled for extra strength and safety.

Colors.

- Galvanized steel, white painted steel or sandalwood painted steel.



Sizes.

- Available in 24" and 36" projections.
- Available in 4', 5' and 6' heights and to fit 4', 5' and 6' wide picture windows.
- Additional custom sizes available up to 9' in height.

MONARCH
Materials Group Inc.



Stif Back® II Area Wall

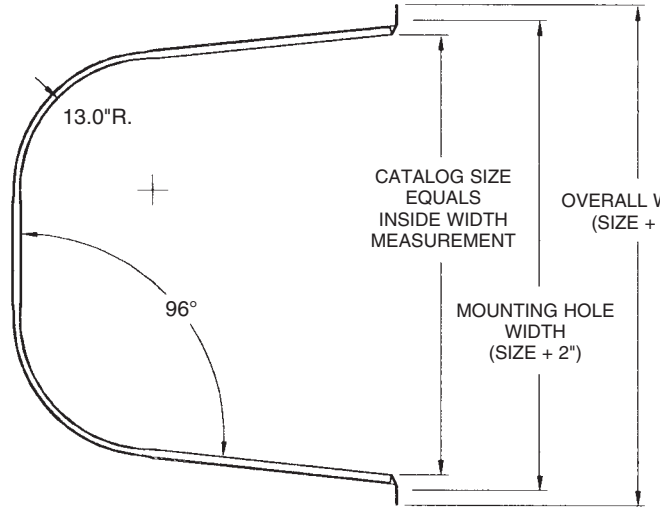
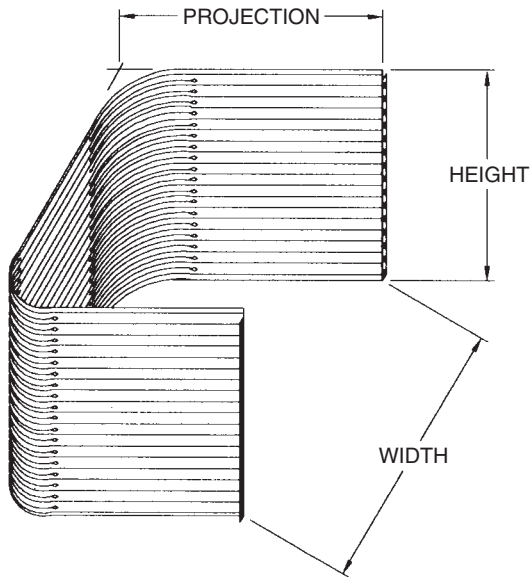

TOP VIEW

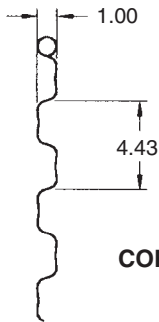

**CORRUGATION
DETAIL**

CATALOG SIZE = INSIDE WIDTH MEASUREMENT

To mounting holes = **WIDTH + 2.0"**

To outside edge of flanges = **WIDTH + 4.0" ***